

TECHNICAL SPECIFICATIONS TYPE 5092 CAST IRON / STAINLESS STEEL

MATERIALS	STANDARD DESIGN	S S DESIGN AISI 316	NORM	
VALVE BODY	DUCTILE CASTIRON	STAINLESS STEEL	GGG40	AISI316
BALL	SOLID POLYURETHANE	AL + NBR		
BOLTS	STAINLESS STEEL		AISI 316	
COVER GASKET	O-RING	NBR RUBBER		
PAINTING	SIGMA PAINT	IN AND OUDSIDE		

**Monti Valves, checkvalves DN 50, ,DN 80, DN 100, DN 150, DN 200, DN 250
pressure loss in cm WC / L/S**

DN50

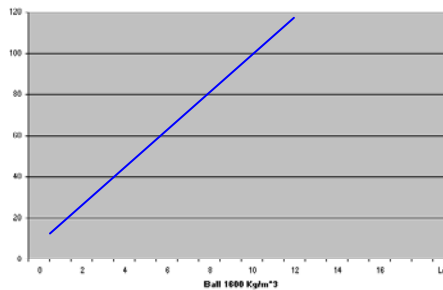

DN80

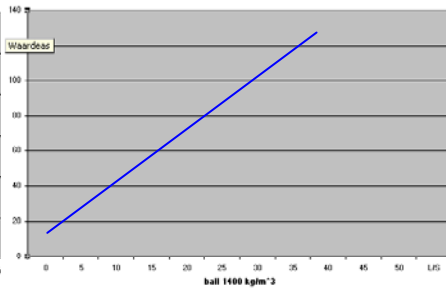

DN100

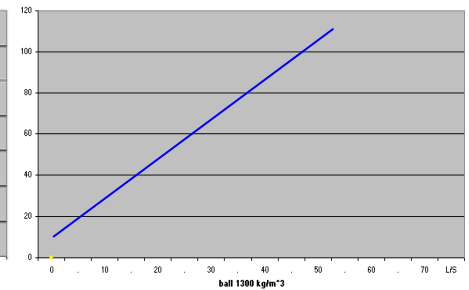

DN150

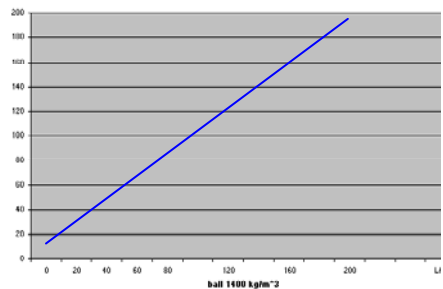

DN200

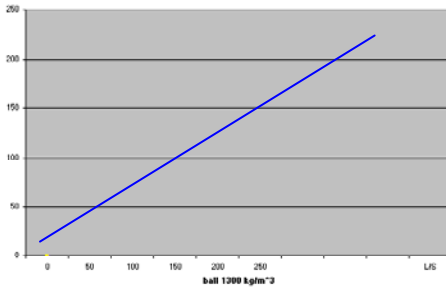

DN250

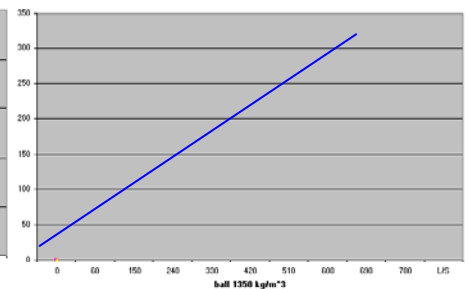

local resistance factor = 0,46

DIMENSIONS

DN	40	50	65	80	100	125	150	200	250	300	350	400	40 TH	50 TH
D BAL	48	60	95	95	120	175	175	240	300	360	420	480	48	60
				FLANGE ACCORDING DIN 2532 PN 10 FLANGE ACCORING ANSI 125										
L DN	180	200	230	260	300	350	400	500	600	700	800	900	140	180
L AM	-	-		241	292		356	495						
H	80	98	143	143	210	250	250	328	400	472	568	690	80	98
WEIGHT	4,2	5,5	13	13	18	37	37	68	112	163	289	416	2,2	3,6

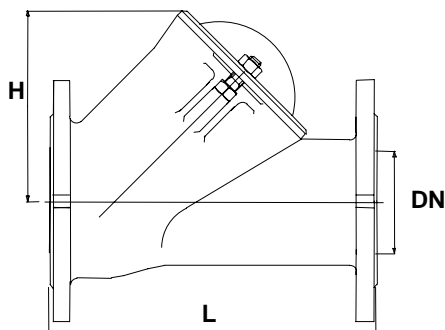

MONTI VALVES B.V.

AMPERESTRAAT 52 – 54 1446 TS PURMEREND
The Netherlands

Tel.: +31 (0)299 641118 FAX.: +31 (0)299 644999

